



Make the Gears Turn More Accurately

高端夹具助力齿轮制造升级

让齿轮传动更精准

C 目录 ontents

- 公司简介
Company profile
- 企业使命
Our mission
- 企业发展优势
Our advantages
- 中国齿轮夹具核心发明者和领航者
The core leader and inventor of gear fixture in China
- 航空专利技术安全稳定可靠
Aviation patent safe and stable
- 产品系列
Product series
 - S级（超高精密夹具）
S class(Ultra precision fixture)
 - E级（极速快换夹具）
E class(Quick change fixture)
 - MINI级（超精密袖珍夹具）
Mini Series(Ultra high precision mini fixture)
 - PARTS(精密零件)-夹具智能心系列
PARTS(precision parts)-Fixture intelligent arbor
 - PARTS(高精度)-内缩型弹性涨套
PARTS(High precision)-Inner clamping collet
 - PARTS(精密零件)-超精密顶尖系列
PARTS(precision parts)-Ultra precision center series
- 业务分布图
Business Map

齿轮快换夹具领先品牌

高端自动化夹具引领者

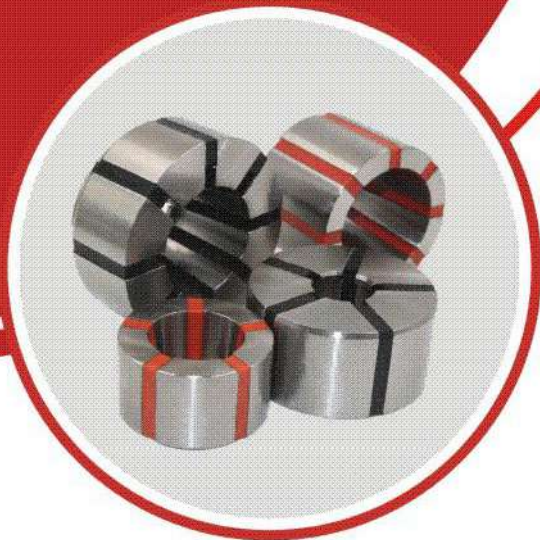

C 公司简介 ompany

公司成立于1992年，主要服务于国内外知名企业。公司始终致力于让齿轮传动更精准的使命，做齿轮快换夹具领跑者，引领高端自动化夹具。

公司设备精良，拥有先进的现代化生产线、数控机加工生产线以及高效精密的计量、检测、试验手段，为产品的高质量提供了可靠的保证。

通过ISO9001:2000质量管理体系认证。公司发展始终坚持以人为本，尊重知识，尊重人才。

The company was founded in 1992 and mainly serves well-known companies at home and abroad. The company has always been committed to the mission of making gear transmission more precise, to be the leader in quick change gear fixtures, and to lead high-end automation fixtures.

The company has excellent production equipment, advanced modern production line, CNC machining production line and high-end precision measurement devices, testing and experimental equipment, which provide reliable guarantee for the high quality of the products.

We have Passed ISO9001: 2000 quality management system certification. The Development of our company is always adhered to people-oriented, respecting knowledge and respecting talents.

M 企业使命
Mission

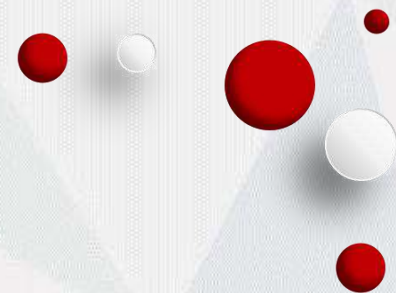

让齿轮传动更精准

MORE PRECISION OF GEAR DRIVING

30年专注 匠心打造

FOCUS FOR 30 YEARS, ORIGINALITY MANUFACTURING

全球制造 东龙品质

GLOBAL MARKETING, DONGLONG QUALITY

高精度齿轮快速换产夹具设计制造

HIGH PRECISION GEAR QUICK CHANGE FIXTURE DESIGN, MANUFACTURE

高精度齿轮快速检测量检具，测量仪器设计制造

HIGH PRECISION GEAR MEASURE DESIGN, MANUFACTURE

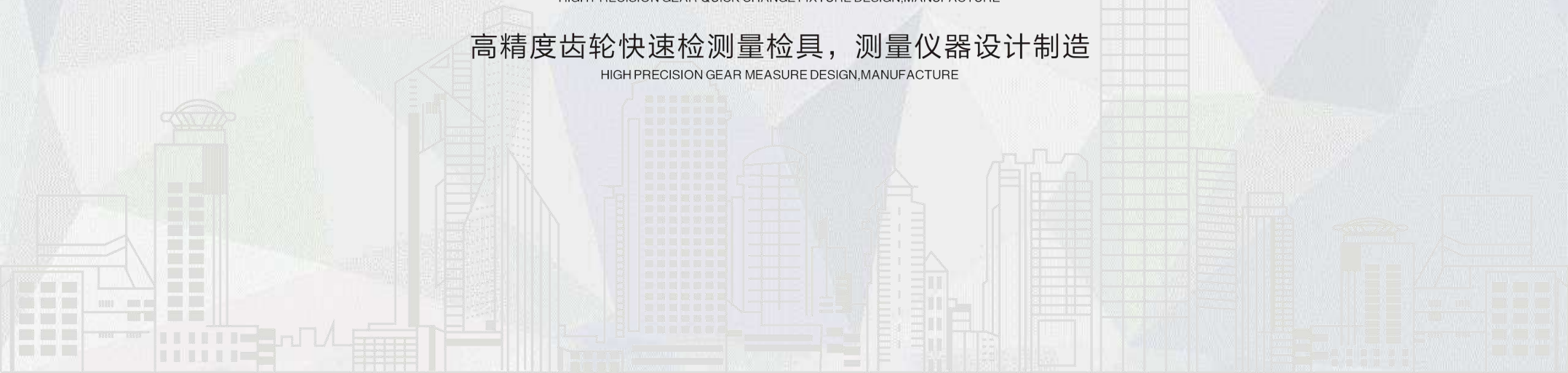

A 企业发展优势 dvantage

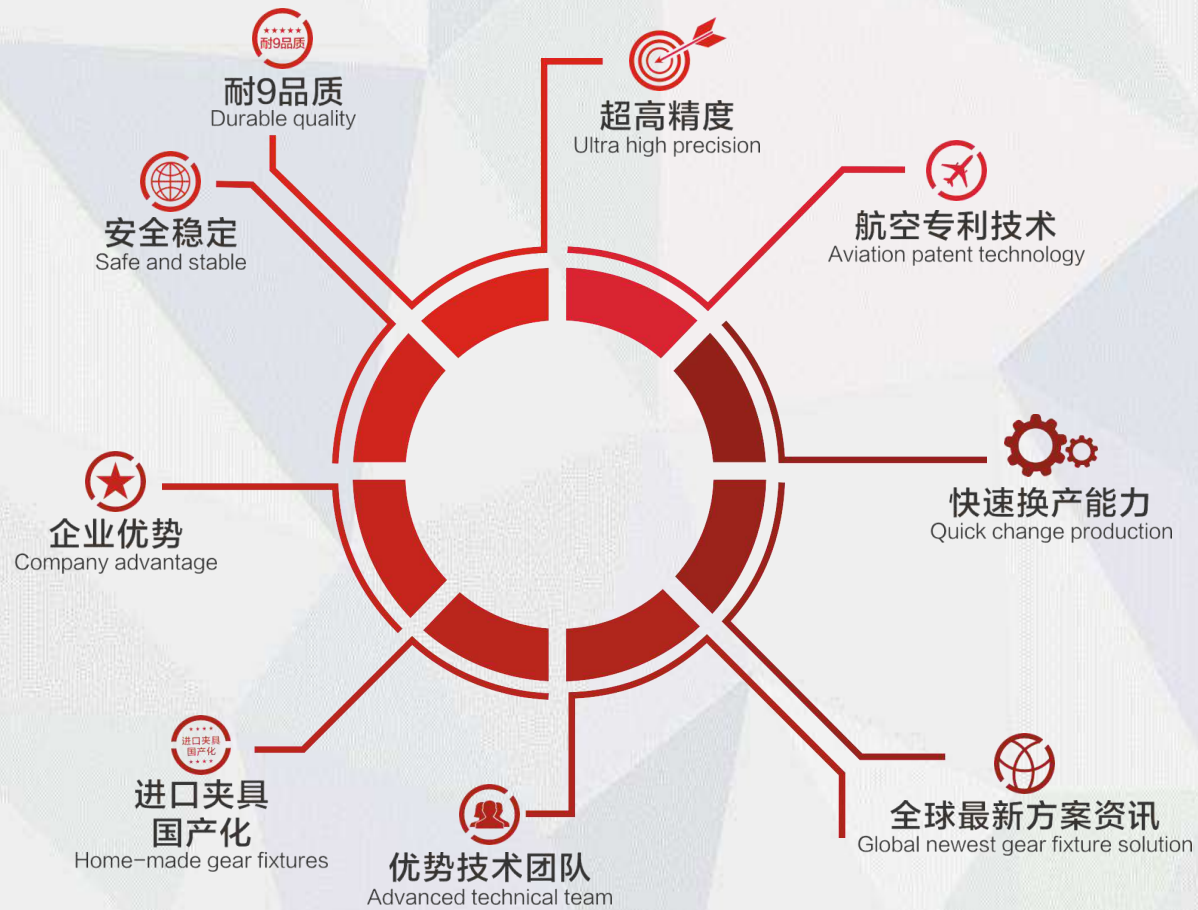

中国齿轮夹具核心发明者和领航者

The core leader and inventor of gear Fixture in China



精心16道 道道真品质

16 Processes Guarantee the high Quality



航空专利技术安全稳定可靠

Aviation patent technology, safe and reliable

航空专利技术

Aviation patent technology



夹具优势

Fixture advantage



提高产品生产率，减少换产时间
Raise the productivity, down the changeover time

实现自动化，减轻劳动强度
Realize automation, reduce labor intensity

实现快速换产，节约夹具成本
Realize quick changeover, save fixture cost

24h全时服务，360° 解决方案
24 hours full service, 360 degree solution

涨套优势

Collet advantage

不易松脱，防屑、防水效果好
Not easy to broken, excellent water and iron scurf proof

超高夹持精度，可达0.003mm
Ultra high clamping precision, up to 0.003mm

硬度高，可达60HRC
High hardness, up to 60hrc

实现无人化智能化生产
Accomplished unmanned intelligent production

高分子材料粘接，寿命超长
Polymer materials adhesive, ultra long life

弹性好，夹持范围大，节省大量夹具体；
Better elasticity, large Clamping range, save Lots of fixture base

更换简便、快捷，可实现快速换产
Easy and quick to change, Accomplished change production



DONGLONG
TOOLS

S级 超高精密夹具

S CLASS (ULTRA PRECISION FIXTURE)

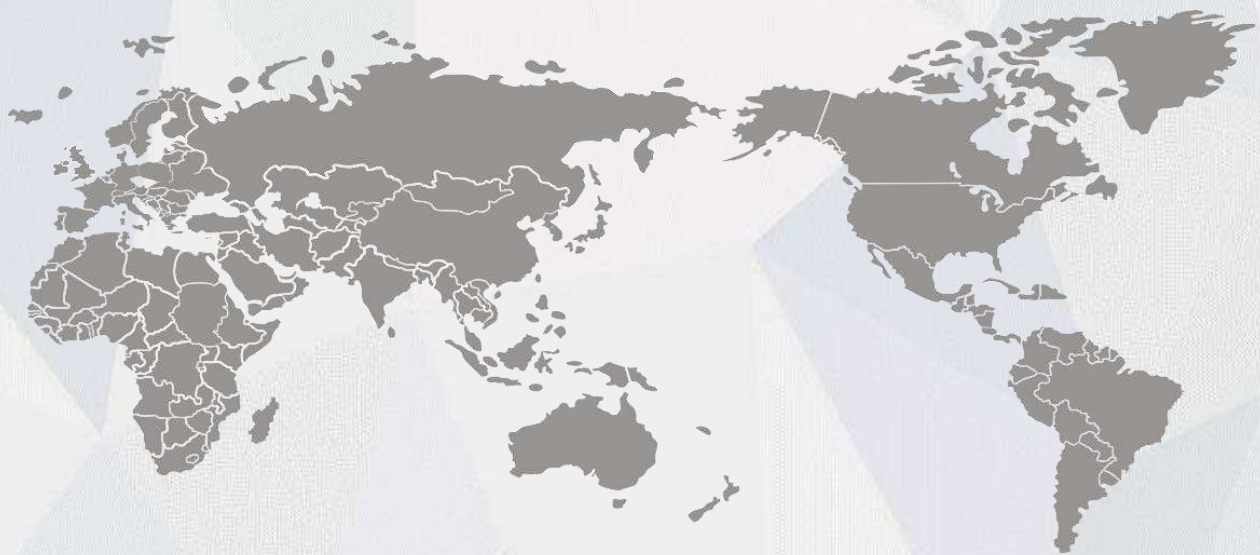

ULTRA PRECISION
FIXTURE

珩齿夹具

Gear Honing Fixture



德国珩齿夹具

Gear Honing Fixture

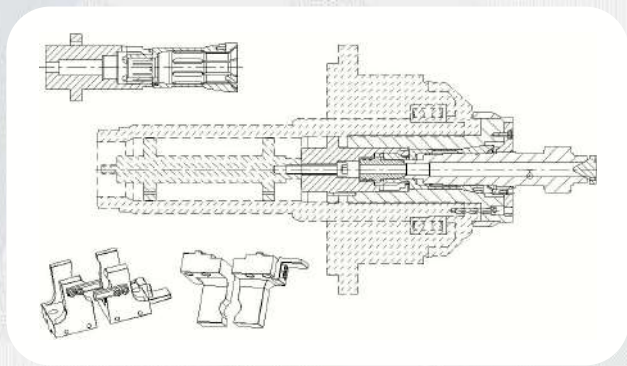
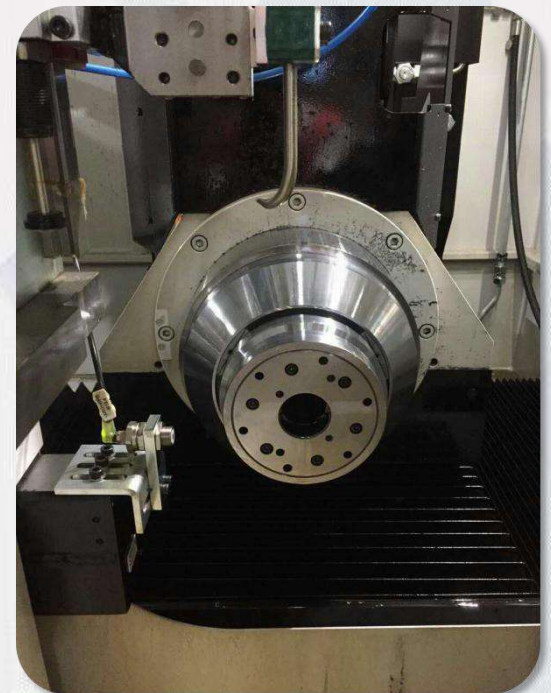
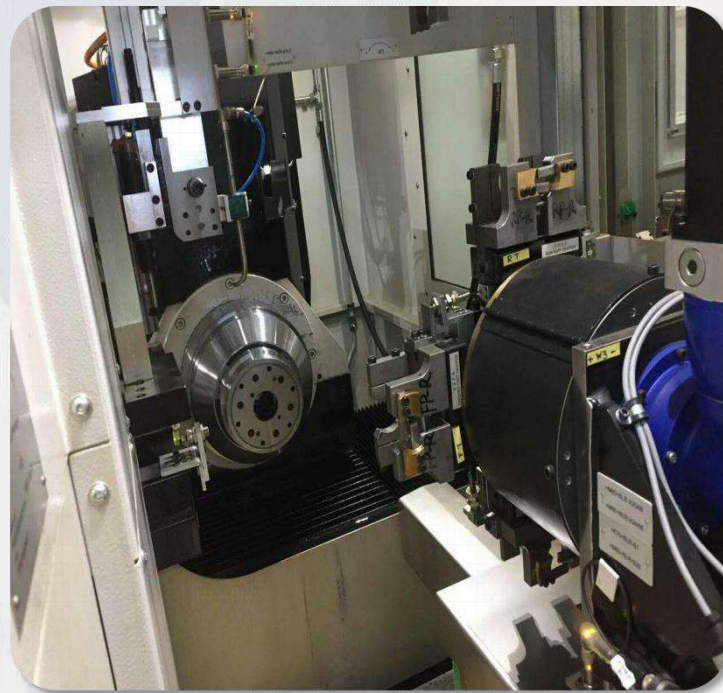

美国机床磨齿夹具

American Machine Grinding Fixture

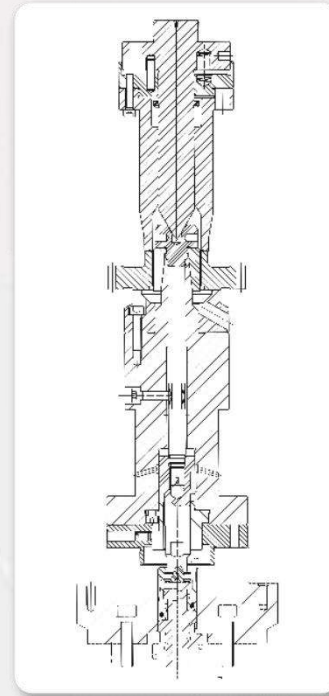

德国机床磨齿夹具

Germany Grinding Fixture



瑞士机床磨齿夹具

Swiss Machine Grinding Fixture



磨齿夹具

Gear Grinding Fixture



日本机床滚齿夹具

Japanese Machine Hobbing Fixture



日本机床滚齿夹具

Japanese Machine Hobbing Fixture

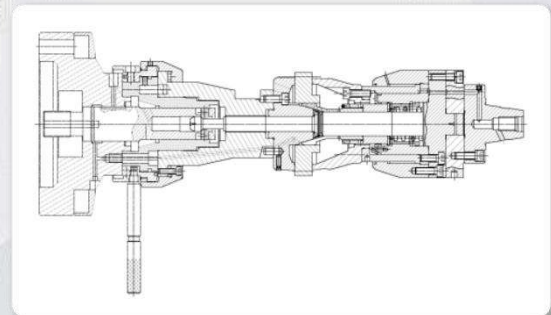

进口机床滚齿夹具

Imported Machine Hobbing Fixture

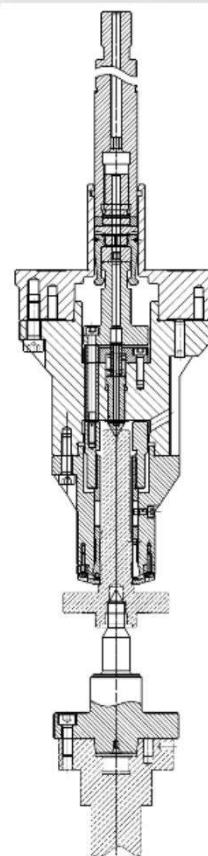

DONGLONG
TOOLS

E级

极速快换系列

E CLASS (QUICK CHANGE FIXTURE)

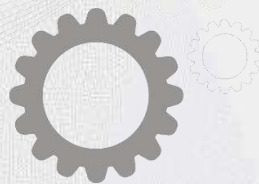

QUICK CHANGE FIXTURE



车夹具

Turning Fixture

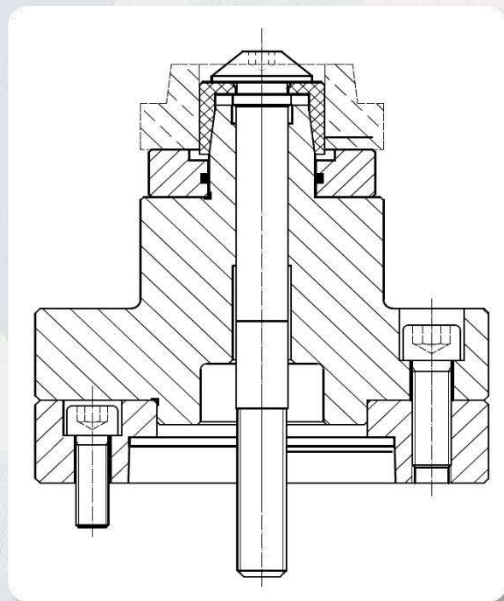

内夹式车夹具

External Clamping Fixture

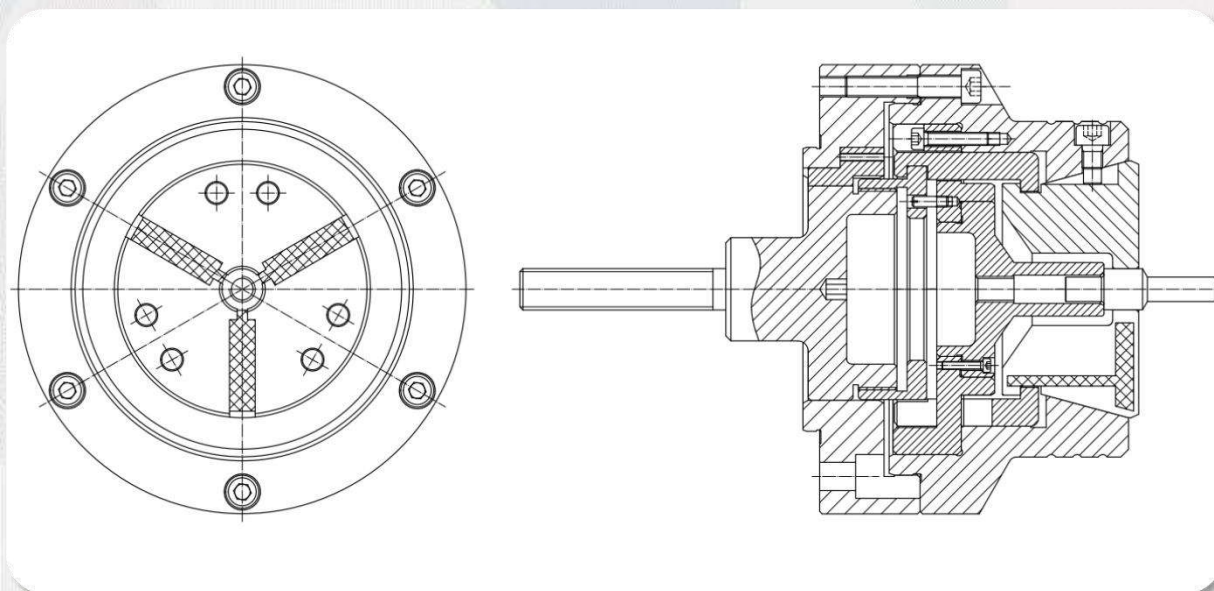

加工中心夹具

CNC Fixture

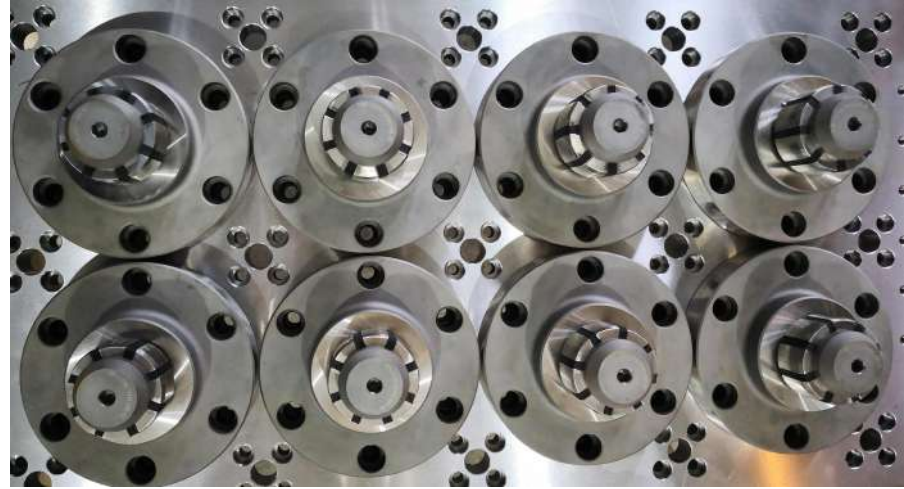

滚齿夹具

Hobbing Fixture



插齿夹具

Gear Shaping Fixture

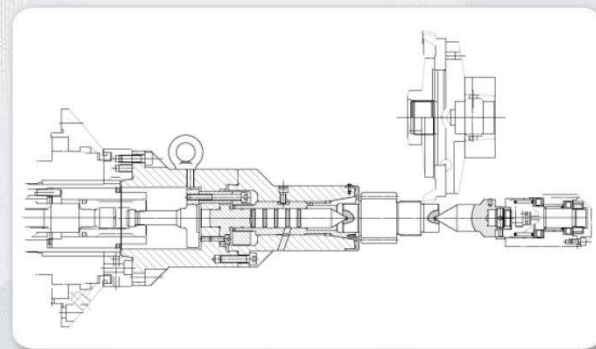
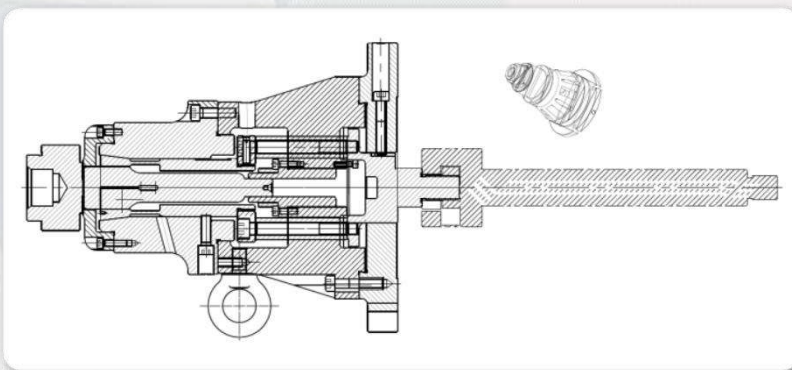

剃齿夹具

Shaving Fixture



DONGLONG
TOOLS

MINI 级

超精密袖珍系列

MINI SERIES (ULTRA HIGH PRECISION
MINI FIXTURE)

(超精密袖珍系列, $6 \leq \text{内孔} < 17$)



小孔滚齿&磨齿夹具

Small size gear hobbing&grinding fixture



ULTRA HIGH PRECISION MINI FIXTURE

小孔夹具

Small Size Fixture

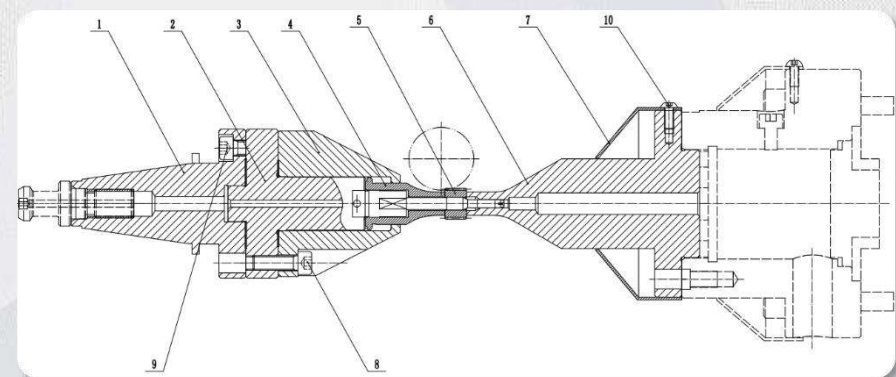
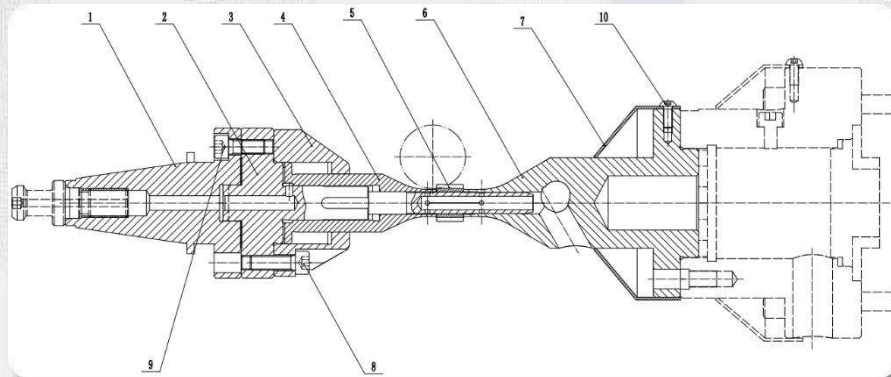
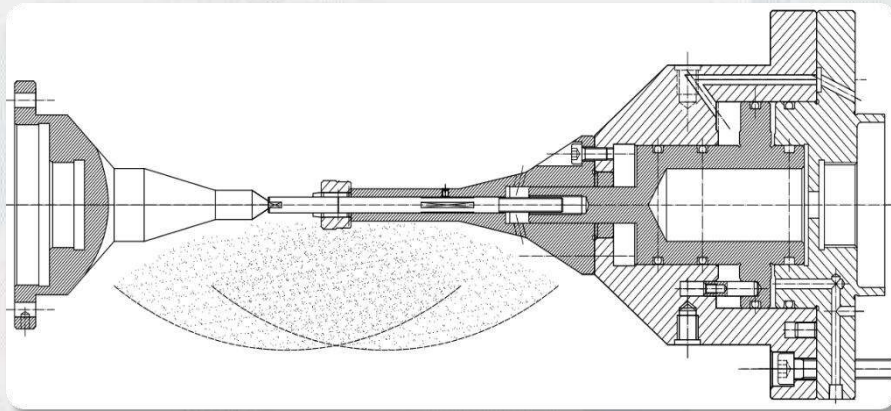

DONGLONG
TOOLS

PARTS级

夹具智能心系列

PARTS (PRECISION PARTS)
FIXTURE INTELLIGENT ARBOR



夹具智能心系列

Fixture intelligent heart series



DONGLONG
TOOLS

PARTS级 内缩型弹性涨套

INNER CLAMPING COLLET



高精度数控机床内缩型弹性涨套

High precision numerical control machine
inner clamping collet

粘接涨套的分类

Kind of segmented collet

1、单锥涨套 Single taper segmented collets

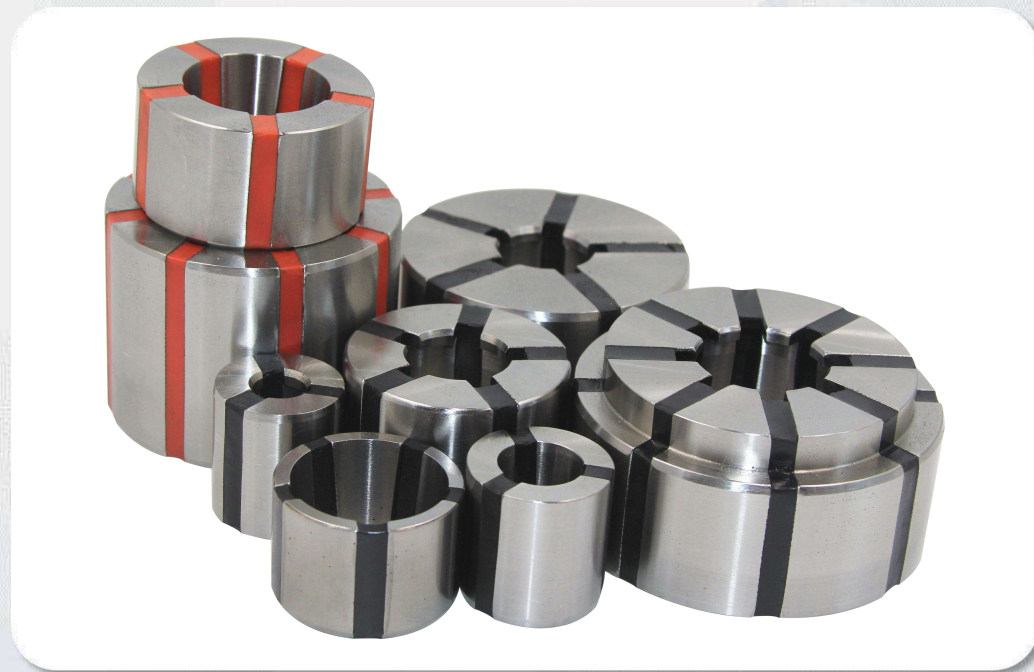

粘接涨套的分类

Kind of segmented collet

2、双锥涨套 Double taper segmented collets

主要用途:

1. 高精度数控滚齿机;
2. 涨紧工件内孔;

Application:

1. High precision numerical control gear hobbing machines
2. Clamping the inner hole of the masterwork

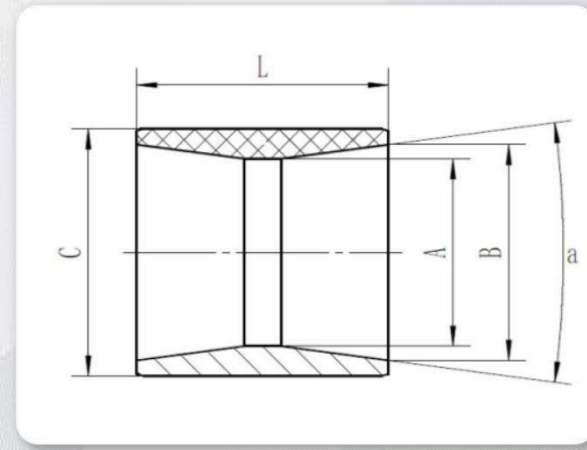

粘接涨套的分类

Kind of segmented collet

3、碟形涨套 Disc type collet

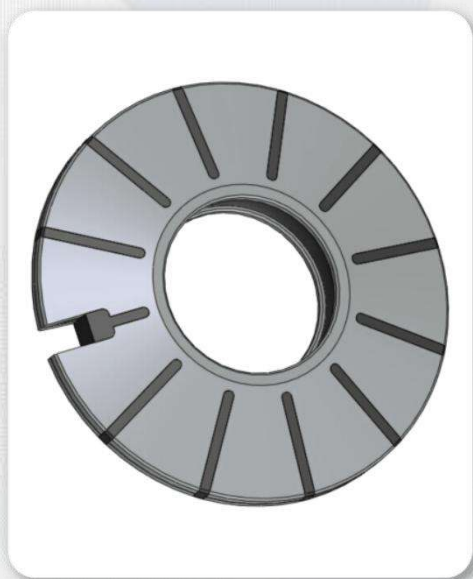

钢制涨套

Steel Collets



DONGLONG
TOOLS

PARTS级

超精密顶尖系列

PARTS (PRECISION PARTS)
ULTRA PRECISION CENTER SERIES



**ULTRA PRECISION
CENTER SERIES**

端驱顶尖

Face drive



非标顶尖系列

Top series



顶尖系列

Top series



检验芯轴

Inspection Mandrel



检具类

Measuring tool



对齿规



槽位置度检具



跨棒距检具



跨球距检具



孔位置度检具



位置度检具

业务分布图

Business Map



▲ 已设办事处或业务点 ▫ 计划业务点

24^h
全时服务
FULL-SERVICE

全时服务
24 HOURS FULL SERVICE

360°
解决方案

360° 解决方案
360 DEGREE SOLUTION



中国 · 西安
XI'AN CHINA



中国齿轮夹具核心发明者和领航者

The Core Leader And Inventor Of Gear Fixture In China

西咸新区远景新能源科技有限公司

Xī'an Envision New Energy Technology Co., Ltd

陕西省西安市西咸新区青年创业园一号楼

Mike : Ph +86-152 0240 1203

mike@envisionnewenergy.com

Rosemary : Ph +86-156 1927 7716

sales1@envisionnewenergy.com